



# **DT ProFab**

**PERFORMANCE SUSPENSIONS**

## **DTPO2101 XHD 94-2002 GEN 2 LIFTED TRACBAR KIT**



**WARNING:** This product can expose you to chemicals including; Hexavalent Chromium which is known to the State of California to cause cancer or birth defects or reproductive harm.  
For more information, visit [www.P65Warnings.ca.gov](http://www.P65Warnings.ca.gov)



## WARNING

## PRE-INSTALLATION NOTES:

- Read and understand all instructions, warnings and cautions in these instructions, before the installation or use of this product. **DO NOT INSTALL** or use this product if there is anything you do not understand in these instructions or related materials.
- Proper installation of DT Profab products requires knowledge of recommended procedures for disassembly/assembly of OE vehicles and components (i.e. steering tie rods, control arms, brake calipers, etc.). Access to OE shop manuals and special tools might be required. Attempting to install this kit without knowledge of these procedures and/or without the proper tools, may affect the safety of your vehicle and/or the performance of these components.
- DT Profab strongly recommends that this kit be installed by a Professional Technician.
- Certain DT Profab products are intended to improve On-Road and Off-Highway performance. Modifying your vehicle for off-road use may result in the vehicle handling differently than a factory equipped vehicle. Use of oversize tires, suspension lifts, body lifts and other suspension modifications may raise your vehicle's center of gravity resulting in an increased tendency for the vehicle to pitch and roll during sudden turns or abrupt maneuvers. Extreme care must be used to prevent loss of control or vehicle roll over. Failure to drive your modified vehicle safely may result in serious injury or death. Drive at reduced speeds to ensure your ability to maintain control of the vehicle under all driving conditions. Always wear seat belts.
- **DO NOT** combine suspension lifts, body lifts or other lift devices. Combined use of lifts may result in unsafe and/or unexpected handling characteristics (see enclosed product safety **WARNING** label).
- The use of larger than OE tire and wheel combinations may reduce the effectiveness of the braking system and increase the amount of pedal pressure necessary to obtain a given braking distance with normal stops and increase the stopping distance in a panic stop.



## CAUTION

## PRODUCT SAFETY LABEL:

- The suspension of this vehicle has been modified to improve **ON and OFF-ROAD PERFORMANCE**.
- As a result, this vehicle may handle differently than factory equipped vehicles.
- Extreme care must be used to prevent loss of control or roll over during sharp turns or abrupt maneuvers.
- Failure to drive this vehicle safely may result in serious injury or death.
- Take time to re-aquaint yourself with **NEW** unique handling characteristics of your vehicle and are confident of your ability to maintain control under all driving conditions.

**Always wear seat belts, and drive safely.**



## CAUTION

Coil springs store energy. Always release the load on coil springs in a slow and controlled manner. Use a safety chain or cable to prevent the possibility of the spring coming loose and causing injury. We recommend using a high quality internal type coil spring compressor when removing and installing springs.

**Warning: Never work under vehicle unless you have jack stands supporting the vehicle.**

**Note:** Prior to installation, carefully inspect the vehicle's steering and drive train components. Be sure to check ball joints, wheel bearings, tie rod ends, track bar, and control arm bushings. Everything must be tight and in good working condition.

- We recommend installation be done by a trained professional.
- Read instructions carefully before attempting installation.
- Front end alignment is necessary upon completion of install.

1. Place vehicle on level ground with the wheels blocked, parking brake set and the transmission in park for automatics or reverse for manual transmission.
2. Raise front of the vehicle so the front wheels are off the ground and support the frame securely on jack stands placed behind the front axle, one on each side of the vehicle and lower vehicle until weight is on jack stands. **Check that the vehicle is secure.**
3. Remove tires and let front axle go to full droop.
4. Remove the ball stud at the frame end of the OEM trac bar. Remove the cotter pin from castle nut, remove nut (22mm wrench). Hit the casting with a hammer to remove the stud from the frame.
5. Remove the bolt (18mm wrench) and nut clip from the axle end of the OEM trac bar. Pull the trac bar free of the vehicle. Retain bolt and nut clip for re-installation of the new DT Trac Bar.
6. Some 94-95 models have a bolt-on brace from the engine cross-member to the cast trac bar mount. Remove and discard this brace.
7. Unbolt the brake line clip from the cross-member.
8. Some 94-95 models use a small ball stud. The tapered OEM cast frame bracket must be drilled out to 5/8" to accept the new bracket bolt. The tapered aluminum adapter is not used on these models.
9. Install the tapered aluminum adapter into the OEM cast frame bracket from the bottom.
10. Mount the new DT Trac Bar Bracket to the frame with a 5/8" flange locknut and a 5/8" x 2 1/2" bolt thru the tapered aluminum adapter just installed. Install the 1/2" x 5" bolt down thru the existing frame hole under the steering box input shaft, then thru the front ear on the DT Bracket. Secure with 1/2" flange locknut. *The head of the bolt will sit at a weird angle. This is okay, tighten the nut, but do not crush the frame.*

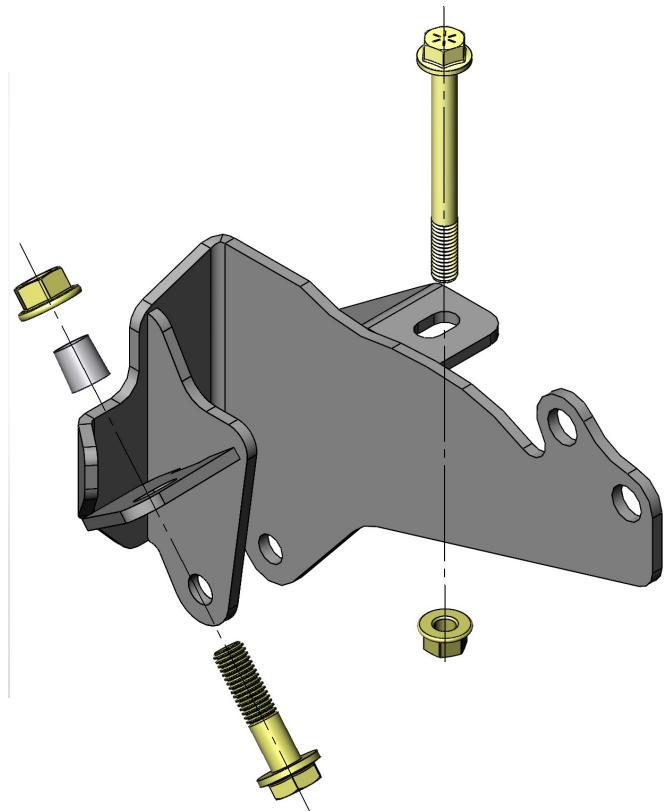

11. Remove the pilot bit from a 3/4" hole saw. With the DT Trac Bar Bracket positioned, use the bracket as a drill guide and drill thru only the backside of the cross-member for the two crush sleeves.
12. Re-install the pilot bit in the hole saw. Use the DT Trac Bar Bracket and just drilled 3/4" holes as a guide, drill only a 1/4" pilot hole thru the front side of the cross-member. *Keep the drill as straight as possible.*
13. Enlarge both of the 1/4" holes on the front side of the cross-member to 1/2".
14. Install the two 3/4" diameter crush sleeves with 1/2" x 2 1/2" bolts with washers on both sides and secure with 1/2" lock washers.

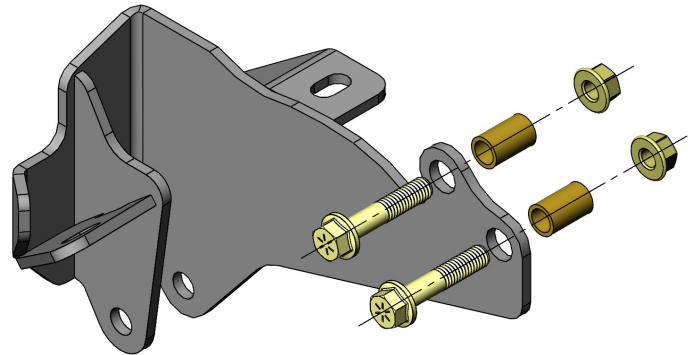

15. Drill pilot hole in cross-member to reattach brake line.

### Trac Bar Assembly

16. Assemble Bushing Adapter by installing Bushings, Lubricate Sleeve, push Sleeve into Bushings.

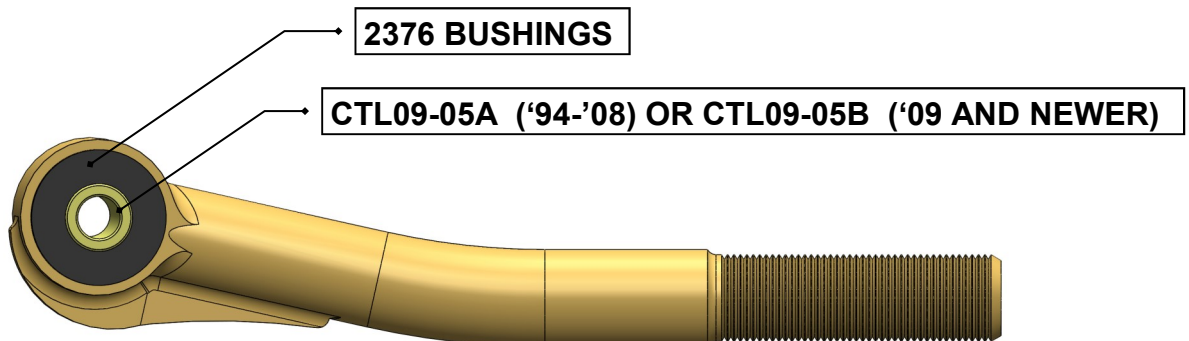

19. For lifted trucks, on the passenger side you need to grind a notch in the spring bucket gusset right above where the Trac Bar will pass so the Trac Bar won't hit the gusset.

20. Install Bushing Adapter and Bearing Adapter with Jam Nuts into Trac Bar. Set the center to center distance to approximately 38". Adjust so that there are equal lengths of threads showing on both Bearing Adapter and Bushing Adapter.

21. Install Trac Bar into axle housing bracket re-using stock bolt and nut clip. *Torque to manufacturer's specification.*

22. Install Bearing End into new DT Trac Bar Bracket.

23. Install 5/8" x 3" bolt, washers and locknut. Turn the Trac Bar Tube to adjust the length to allow installation of bolt. Keep the exposed threads at both adapters equal. *Torque to 220 lb ft.*

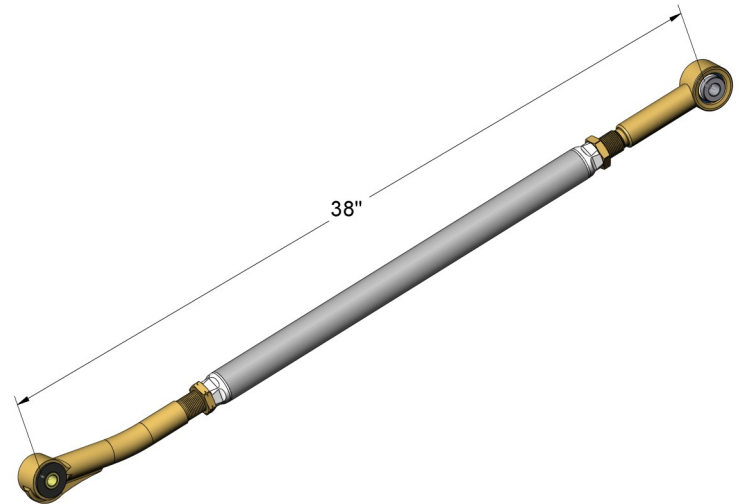

### Centering Front Axle

24. Before you install the tires, put the jack stands under the axle so it will load the front suspension. Install the Measuring Tool provided on suspension link arm. Measure distance between tool and frame. Measure both sides. Adjust Trac Bar in or out until axle is within 1/16" side to side.

25. Tighten Jam Nuts, these need to be really tight, as torque rating is 525 lb ft.

26. **Recheck that all fasteners are properly tightened!**

27. After a test drive to center the steering wheel, adjust relay link and retest until wheel is centered.

28. **It is the ultimate buyers responsibility to have all bolts and nuts checked for tightness after the first 500 miles and then every 1000 miles.**

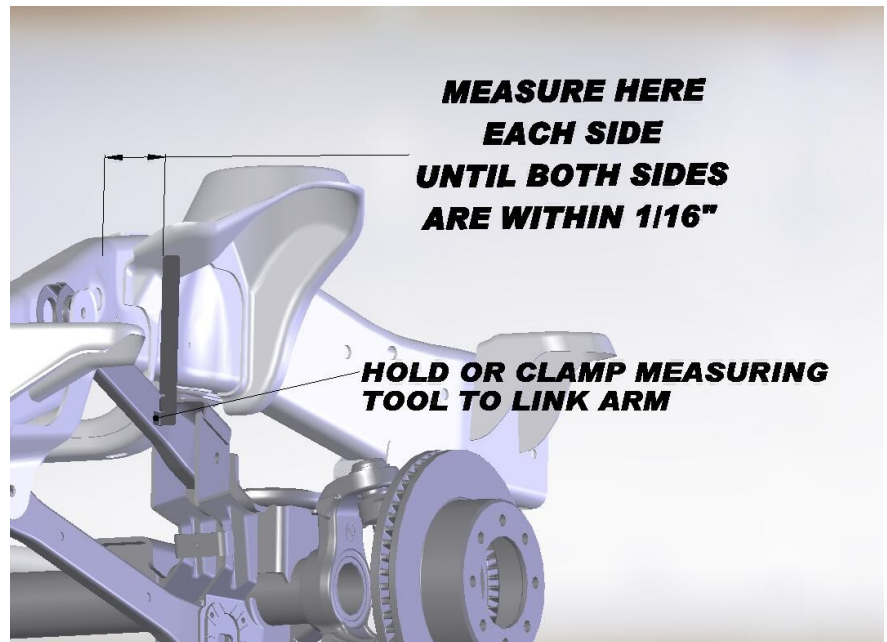

ITEM NO.	PART NUMBER	DESCRIPTION	QTY.
1	02001	BRACKET 3 1/2" - 6"	1
5	02000-023	TUBE-CRUSH SLEEVE	2
6	02000-014	TRACBAR FILLER	1
7	BOLT-1/2-13x2.50"-GR8	1/2"-13 X 2.50" GRD 8 FLANGE BOLT	2
8	FLGNUT 50	1/2"-13 FLANGE LOC NUT	3
9	BOLT-5/8-11x2.50"-GR8	5/8"-11 X 2.50" GRD 8 FLANGE BOLT	1
10	FLGNUT 62	5/8"-11 FLANGE LOC NUT	2
11	BOLT 1/2-13X5.00"-GR8	1/2"-13 X 5.00" GRD 8 FLANGE BOLT	1
12	BOLT-5/8-11x3.00"-GR8	5/8"-11 X 3.00" GRD 8 FLANGE BOLT	1

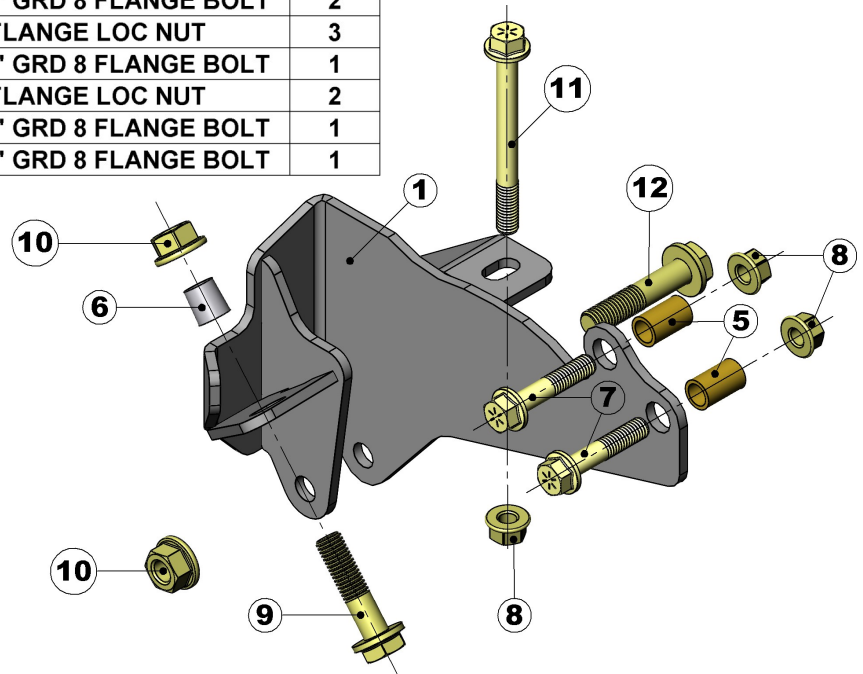

ITEM NO.	PART NUMBER	DESCRIPTION	QTY.
1	DTP02000-030	TRACBAR BEARING END	1
2	02000-015	TRAC-BAR	1
3	02000-017	BUSHING ADAPTER	1
4	JNL18S	1 1/8" - 12 JAM NUT LEFT-HAND	1
5	JNR18S	1 1/8" - 12 JAM NUT	1
6	2376	BUSHING	2
7	CTL09-05A	TRAC BAR CRUSH SLEEVE	1
8	CTL09-05B	SLEEVE '08 UP TRAC BAR	1

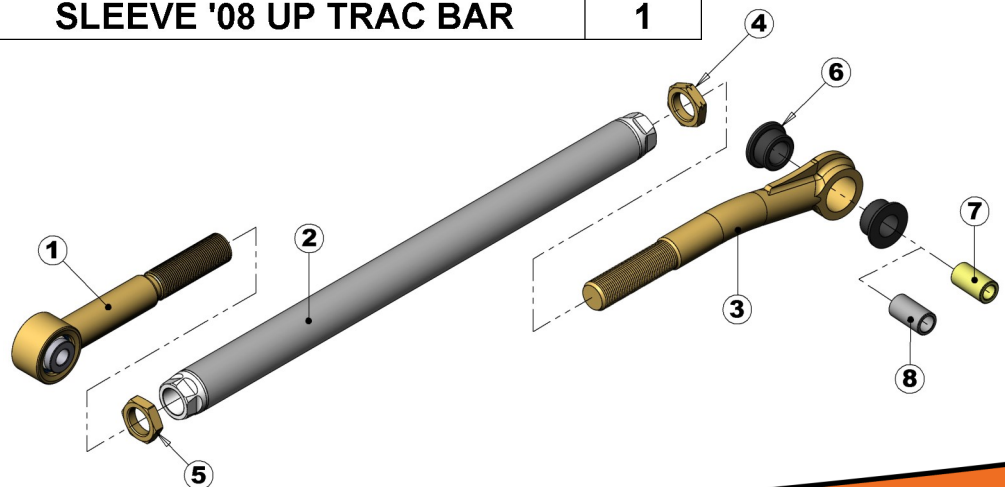



## WARNING

## POST-INSTALLATION NOTES:

- ⇒ Check all fasteners for proper torque before driving the vehicle for the first time with this kit.
- ⇒ Check all fasteners for proper torque after the first 500 miles, also it is recommended during routine vehicle servicing.
- ⇒ The components included in this kit require regular inspection for wear or damage. Worn, damaged or loose parts can fail suddenly resulting in loss of control of the vehicle and personal injury.
- ⇒ In ALL steering and suspension positions, check to ensure that there is adequate clearance between ALL rotating, moving, fixed and heated members. Ensure adequate clearance around steering components, exhaust components, brake lines, fuel lines, fuel tank and electrical wiring.
- ⇒ Visually inspect components for wear or damage after each off-road use and during routine vehicle servicing. Worn, damaged or loose parts can fail suddenly resulting in loss of control of the vehicle and personal injury.
- ⇒ In general, larger tire and wheel combinations may increase stress and wear on OEM components leading to increased maintenance and greater risk of component failure.
- ⇒ Property damage or personal injury may result.
- ⇒ Large tire and wheel combinations may also alter speedometer calibration, reduce braking effectiveness and alter vehicle center of gravity height (See product safety warnings).
- ⇒ For questions or suggestions, contact our Technical Assistance Department at (928) 776-4129.

## TORQUE SPECIFICATIONS:

1/4 FASTENERS.....	10 FT.-LBS.
5/16 FASTENERS.....	17 FT.-LBS.
3/8 FASTENERS.....	30 FT.-LBS.
7/16-14 FASTENERS .....	50 FT.-LBS.
7/16-20 FASTENERS .....	55 FT.-LBS.
1/2-13 FASTENERS.....	75 FT.-LBS.
1/2 U-BOLTS.....	65-80 FT.-LBS.
9/16 FASTENERS.....	110 FT.-LBS.
9/16 GRADE 8 FASTENERS.....	170 FT.-LBS.
9/16 U-BOLTS.....	75-90 FT.-LBS.
5/8 FASTENERS.....	150 FT.-LBS.
5/8 U-BOLTS.....	85-110 FT.-LBS.
3/4 FASTENERS.....	175 FT.-LBS.

## GLOSSARY OF TERMS:

DS	Drivers side of the vehicle
PS	Passengers side of the vehicle
RH	Right hand thread (Clockwise to tighten)
LH	Left hand thread (Counterclockwise to tighten)
OE	Original equipment

# WARRANTY

Thank you for your purchase of a DT PROFAB product. We appreciate your business.

## IMPORTANT INFORMATION:

### Notice to Owner Operator, Dealer and Installer:

**Please make sure your Dealer/Installer explains and delivers all warning notices, warranty forms and instruction sheets included with DT PROFAB product.** DT PROFAB reserves the right to update as necessary, without notice, and will not be held responsible for misprints, changes or variations made by vehicle manufacturers.

**Please note that certain mechanical aspects of any suspension lift product may accelerate ordinary wear of original equipment components.** The installation of certain DT PROFAB products may void the vehicle's factory warranty as it pertains to certain covered parts; it is the consumer's responsibility to check with their local dealer for warranty coverage before installation of any DT PROFAB product.

### Warranty and Return policy:

DT PROFAB warrants its full line of products to be free from defects in workmanship and materials. DT PROFAB's obligation under this warranty is limited to repair or replacement, at DT PROFAB's option, of the defective product. **Any and all costs of removal, installation, freight or incidental or consequential damages are expressly excluded from this warranty.** DT PROFAB is not responsible for damages and/or warranty of other vehicle parts related or non-related to the installation of DT PROFAB product. A consumer who makes the decision to modify his vehicle with aftermarket components of any kind will assume all risk and responsibility for potential damages incurred as a result of their chosen modifications. Warranty coverage does not include consumer opinions regarding ride comfort, fitment and design. Warranty claims can be made directly with DT PROFAB or at any authorized DT PROFAB dealer.

### Claims NOT Covered Under DT PROFAB Warranty

- **Parts subject to normal wear, to include bushings, bump stops, ball joints, heim joints**
- **Coating Finish after 90 days**
- **Discontinued products at DT PRODUCTS, INC/DT PROFAB discretion**
- **Bent or dented product**
- **Leaf or coil springs used without proper bump stops**
- **Products with evident damage caused by abrasion or contact with other items**
- **Damage caused as a result of not following recommendations or requirements in the installation manuals**
- **Products used in applications other than listed in DT PROFAB's catalog**
- **Components or accessories used in conjunction with other manufacturer's systems**
- **Warranty claims without *Proof of Purchase* DT PROFAB accepts no responsibility for any altered product, improper installation, lack of or improper maintenance, or improper use of our products.**



**DT PRO FAB**  
Information & order Info  
[www.dtprofab.com](http://www.dtprofab.com)  
Email at [sales@dtprofab.com](mailto:sales@dtprofab.com)  
Phone 928.776.4129