



DT ProFab

PERFORMANCE SUSPENSIONS

DTPO2106H2 03-12

LIFTED TRACK BAR KIT



WARNING: This product can expose you to chemicals including; Hexavalent Chromium which is known to the State of California to cause cancer or birth defects or reproductive harm.
For more information, visit www.P65Warnings.ca.gov



WARNING

PRE-INSTALLATION NOTES:

- Read and understand all instructions, warnings and cautions in these instructions, before the installation or use of this product. **DO NOT INSTALL** or use this product if there is anything you do not understand in these instructions or related materials.
- Proper installation of DT Profab products requires knowledge of recommended procedures for disassembly/assembly of OE vehicles and components (i.e. steering tie rods, control arms, brake calipers, etc.). Access to OE shop manuals and special tools might be required. Attempting to install this kit without knowledge of these procedures and/or without the proper tools, may affect the safety of your vehicle and/or the performance of these components.
- DT Profab strongly recommends that this kit be installed by a Professional Technician.
- Certain DT Profab products are intended to improve On-Road and Off-Highway performance. Modifying your vehicle for off-road use may result in the vehicle handling differently than a factory equipped vehicle. Use of oversize tires, suspension lifts, body lifts and other suspension modifications may raise your vehicle's center of gravity resulting in an increased tendency for the vehicle to pitch and roll during sudden turns or abrupt maneuvers. Extreme care must be used to prevent loss of control or vehicle roll over. Failure to drive your modified vehicle safely may result in serious injury or death. Drive at reduced speeds to ensure your ability to maintain control of the vehicle under all driving conditions. Always wear seat belts.
- **DO NOT** combine suspension lifts, body lifts or other lift devices. Combined use of lifts may result in unsafe and/or unexpected handling characteristics (see enclosed product safety **WARNING** label).
- The use of larger than OE tire and wheel combinations may reduce the effectiveness of the braking system and increase the amount of pedal pressure necessary to obtain a given braking distance with normal stops and increase the stopping distance in a panic stop.



CAUTION

PRODUCT SAFETY LABEL:

- The suspension of this vehicle has been modified to improve **ON and OFF-ROAD PERFORMANCE**.
- As a result, this vehicle may handle differently than factory equipped vehicles.
- Extreme care must be used to prevent loss of control or roll over during sharp turns or abrupt maneuvers.
- Failure to drive this vehicle safely may result in serious injury or death.
- Take time to re-aquaint yourself with **NEW** unique handling characteristics of your vehicle and are confident of your ability to maintain control under all driving conditions.

Always wear seat belts, and drive safely.



CAUTION

Coil springs store energy. Always release the load on coil springs in a slow and controlled manner. Use a safety chain or cable to prevent the possibility of the spring coming loose and causing injury. We recommend using a high quality internal type coil spring compressor when removing and installing springs.

DTPO2106H2 03-11 LIFTED TRACK BAR KIT

Check your package that it has all the components shown in the layout drawing. (see attached sheet)

NOTE: If you are also installing a DT Pro Fab Steering Stabilizer Brace, install this Track Bar first.

Warning: Never work under vehicle unless you have jack stands supporting the vehicle

1. Place vehicle on level ground with the wheels blocked, parking brake set and the transmission in park for automatics or reverse for manual transmission.
2. Raise front of the vehicle so the front wheels are off the ground and support the frame securely on jack stands placed behind the front axle, one on each side of the vehicle and lower vehicle until weight is on jack stands. **Check that the vehicle is secure.**
3. Remove tires and let the front axle go to full droop.
4. To provide access to the track bar to axle retaining bolt, remove the nut from relay link ball stud at the tie rod. Hit the tie rod to remove the stud. **DO NOT HIT THE BALL STUD HOUSING OR STUD THREADS.**
5. Remove the bolt (18 mm wrench) at the axle end of the Track bar. Pull the Track bar free from the axle bracket. Retain the bolt and nut clip for re-installation of the new DT Track Bar later.
6. Remove the bolt and nut at the frame bracket end of the track bar and remove the OEM track bar. **Note:** The diameter of this bolt will be 9/16" or 5/8" depending on the year of the truck. If the bolt hole is 9/16", it will need to be drilled out to 5/8". The new DT Bracket uses a 5/8" bolt.
7. Position the new DT Bracket, bracket brace, and spacer on the frame as shown in the following image and bolt the components together with the 5/8" x 3 1/2" flange bolt and nut. Make the bolt snug but not too tight at this point.

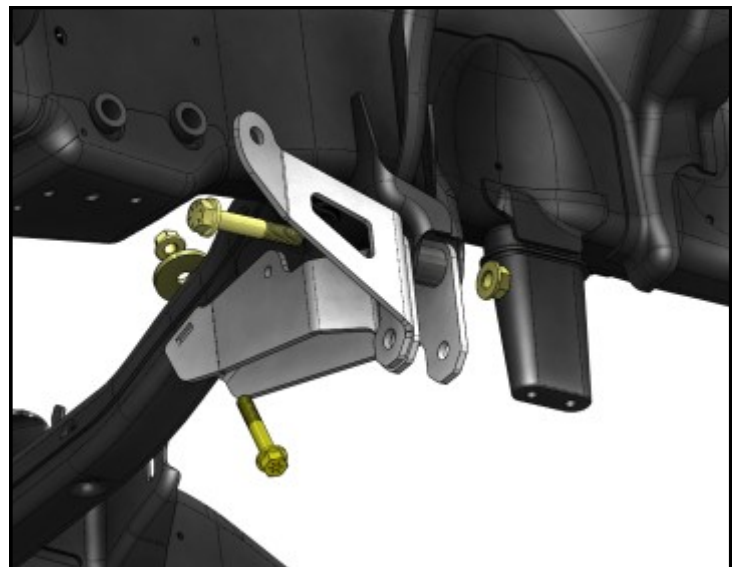

8. Install the 1/2" x 3" bolt up thru the slotted hole in the DT Bracket then thru the existing slotted holes in the cross member under the driver's side of the engine. Install the large 1/2" washer and locknut at the top of the cross member. *Tighten the nut, but do not crush the frame.*

9. With the DT Frame Bracket in position, take a 3/8" diameter drill bit and using the bracket as a guide, drill thru the front side of the cross member only. NOTE: an angle drill eases this operation. The frame may be marked and center punched. Then remove the bracket and drill through the front side of the cross member. Reinstall the bracket.

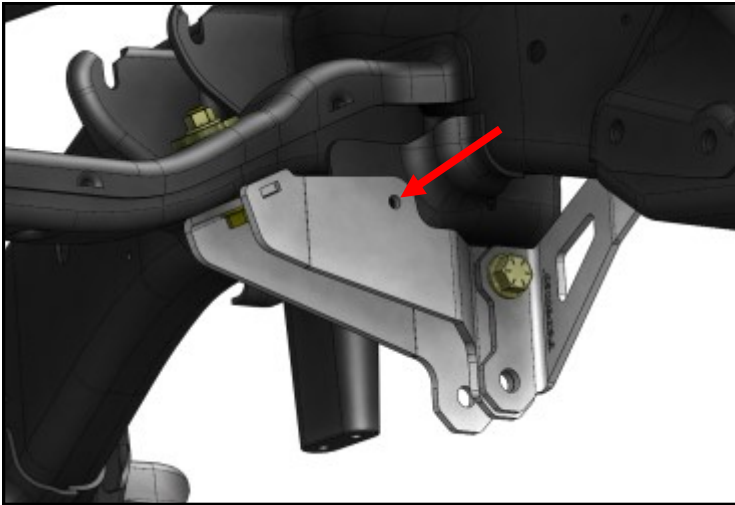

10. Install the 3/8" x 1" flange bolt and flanged locknut through the front of the DT Bracket

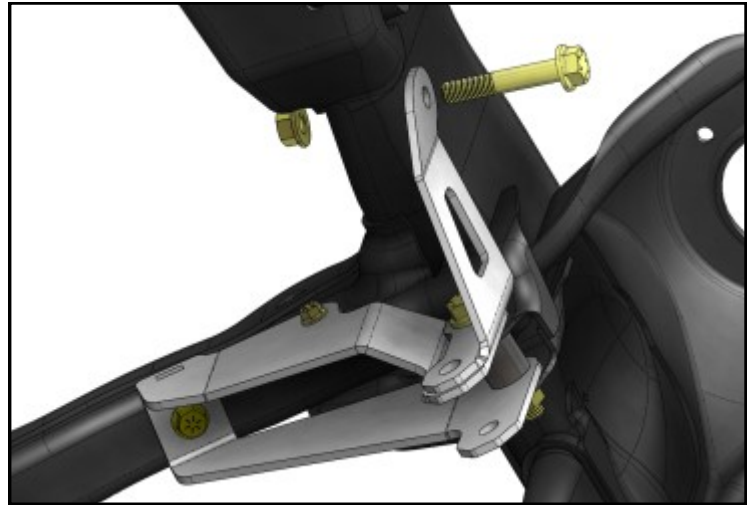

and frame cross member. *Torque to 45 lb ft.*

11. Using the bracket brace as a guide, drill a 5/8" hole through the frame. Install one 5/8"x3 1/2" flange bolt through the bracket brace and the frame as seen in the above image. Tighten a 5/8" flange lock nut onto the end of the bolt.

ITEM NO.	PART NUMBER	DESCRIPTION	QTY.
1	02106H2-BRACKET	TRACK-BAR MOUNT - 3" DROP	1
2	02106H2-03	BRACKET; BRACE	1
3	DRTB1012	SPACER '09-'10 OE TRACBAR BRKTS	1
4	FLGBOLT62C350GRD8	5/8"-11 X 3.50" GRD 8 FLANGE BOLT	2
5	FLGBOLT62C300GRD8	5/8"-11 X 3.00" GRD 8 FLANGE BOLT	1
6	FLGNUT 62	5/8"-11 FLANGE LOC NUT	3
7	FLGBOLT50C300_GR8	1/2"-13 X 3.00" GRD 8 FLANGE BOLT	1
8	FLGNUT 50	1/2"-13 FLANGE LOC NUT	1
9	2INCH WASHER	2.00" OD WASHER	1
10	FLGBOLT37C100_GR8	3/8"-16 X 1.00" GRD 8 FLANGE BOLT	1
11	FLGNUT37	3/8"-16 FLANGE NUT	1

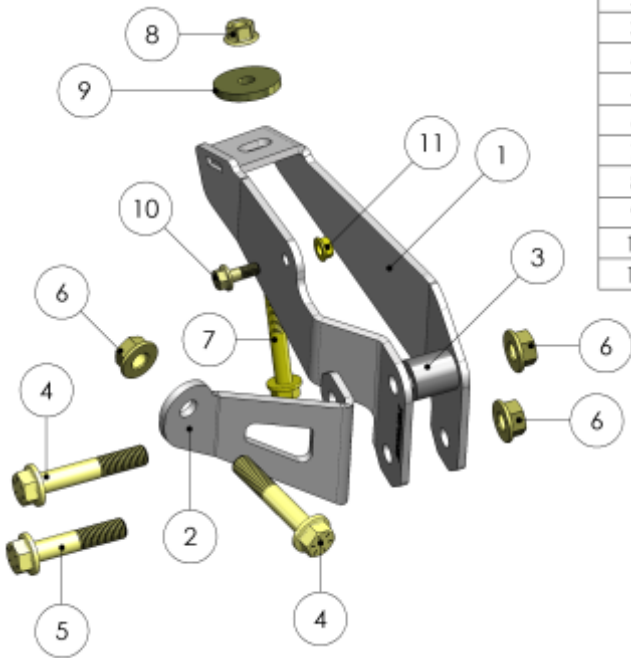

ITEM NO.	PART NUMBER	DESCRIPTION	QTY.
1	02106-001	Formed Ram TracBar	1
2	04012-400	Tracbar Adjuster Tube	1
3	02000-017 ASSY	Ram TracBar Bushing Adapter	1
4	JNR18S	1 1/8"-12 RH Jam Nut	2
5	JNL18S	1 1/8"-12 LH Jam Nut	2
6	2376	BUSHING	2
7	CTL09-05A	TRAC BAR CRUSH SLEEVE	1
8	CTL09-05B	SLEEVE '08 UP TRAC BAR	1
9	DRTB1002-5	SPACER; TRACBAR; 1.0" x 5/8"; FITS COM 16T	2
10	02000-028	MEASURING TOOL	1

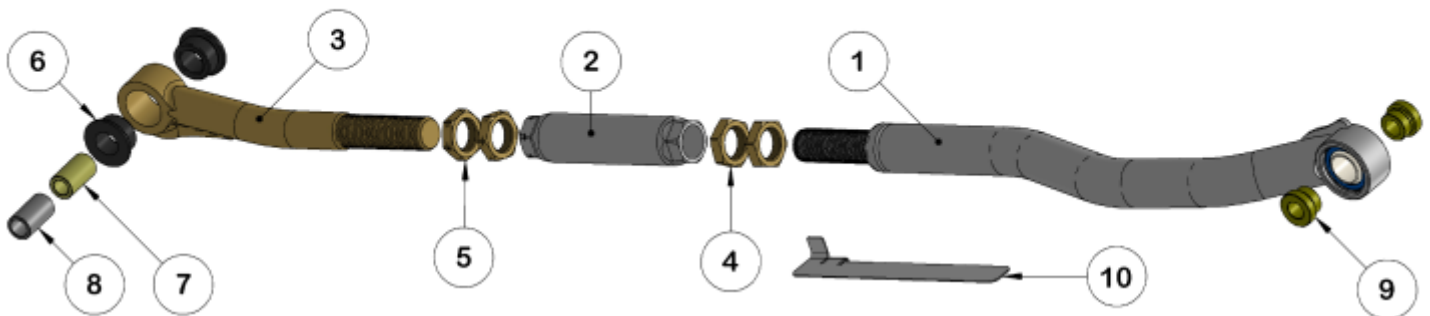

12. Assemble your new track bar as shown in the diagram above. **Note: Do not tighten the Jam Nuts yet. We recommend that you lightly coat the threads with antiseize.** Two bushing sleeves are provided (Item # 7 and 8). Use the factory bolt from the axle end of your OEM track bar to determine what size sleeve is needed for your truck.

13. Install the bushing end of the track bar into the axle housing bracket reusing the stock bolt and nut clip. *Torque to manufacturer's specification.*
14. Install the bearing end into the new DT Pro Fab Bracket with the 5/8"x3" flange bolt and flange lock nut. (Adjust the length of the track bar to line up the bolt holes if needed) *Torque to 220 lb ft.*
15. Tighten the previously installed 5/8"x3 1/2" bolt fastening the new bracket to the frame. *Torque to 220 lb ft.*



Centering Front Axle

16. Before you install the tires, put jack stands under the front axle so it will load the front suspension. Install the measuring tool provided on the suspension link arm as seen in the following image. Measure the distance between the tool and the frame. Measure both sides. Adjust the track bar in or out until the axle is within 1/16" side to side.
17. Tighten Jam Nuts, these need to be really tight, as torque rating is 525 lb ft.
18. Reinstall relay link to tie rod. *Torque nut to manufacturer's specification.*
- 19. Recheck that all fasteners are properly tightened!**
20. After a test drive to center the steering wheel, adjust relay link and retest until wheel is centered.
21. It is the ultimate buyers responsibility to have all bolts and nuts checked for tightness after the first 500 miles and then every 1000 miles.

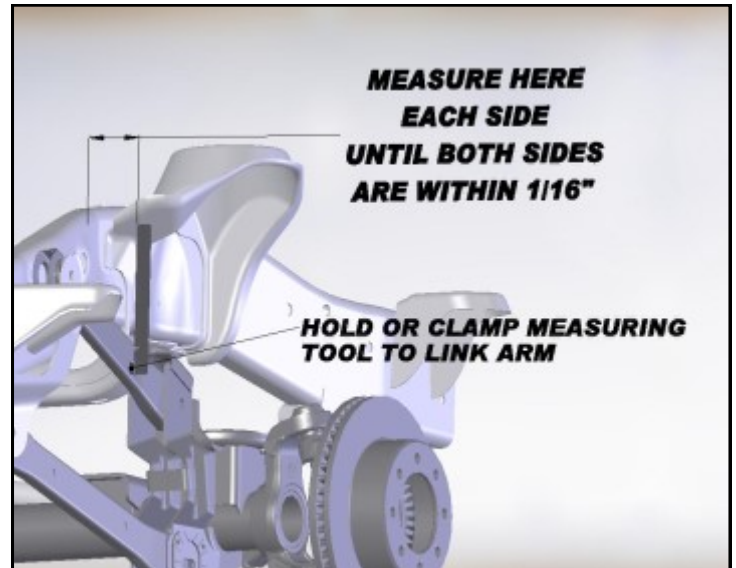



WARNING

POST-INSTALLATION NOTES:

- ⇒ Check all fasteners for proper torque before driving the vehicle for the first time with this kit.
- ⇒ Check all fasteners for proper torque after the first 500 miles, also it is recommended during routine vehicle servicing.
- ⇒ The components included in this kit require regular inspection for wear or damage. Worn, damaged or loose parts can fail suddenly resulting in loss of control of the vehicle and personal injury.
- ⇒ In ALL steering and suspension positions, check to ensure that there is adequate clearance between ALL rotating, moving, fixed and heated members. Ensure adequate clearance around steering components, exhaust components, brake lines, fuel lines, fuel tank and electrical wiring.
- ⇒ Visually inspect components for wear or damage after each off-road use and during routine vehicle servicing. Worn, damaged or loose parts can fail suddenly resulting in loss of control of the vehicle and personal injury.
- ⇒ In general, larger tire and wheel combinations may increase stress and wear on OEM components leading to increased maintenance and greater risk of component failure.
- ⇒ Property damage or personal injury may result.
- ⇒ Large tire and wheel combinations may also alter speedometer calibration, reduce braking effectiveness and alter vehicle center of gravity height (See product safety warnings).
- ⇒ For questions or suggestions, contact our Technical Assistance Department at (928) 776-4129.

TORQUE SPECIFICATIONS:

1/4 FASTENERS.....	10 FT.-LBS.
5/16 FASTENERS.....	17 FT.-LBS.
3/8 FASTENERS.....	30 FT.-LBS.
7/16-14 FASTENERS	50 FT.-LBS.
7/16-20 FASTENERS	55 FT.-LBS.
1/2-13 FASTENERS.....	75 FT.-LBS.
1/2 U-BOLTS.....	65-80 FT.-LBS.
9/16 FASTENERS.....	110 FT.-LBS.
9/16 GRADE 8 FASTENERS.....	170 FT.-LBS.
9/16 U-BOLTS.....	75-90 FT.-LBS.
5/8 FASTENERS.....	150 FT.-LBS.
5/8 U-BOLTS.....	85-110 FT.-LBS.
3/4 FASTENERS.....	175 FT.-LBS.

GLOSSARY OF TERMS:

DS	Drivers side of the vehicle
PS	Passengers side of the vehicle
RH	Right hand thread (Clockwise to tighten)
LH	Left hand thread (Counterclockwise to tighten)
OE	Original equipment

WARRANTY

Thank you for your purchase of a DT PROFAB product. We appreciate your business.

IMPORTANT INFORMATION:

Notice to Owner Operator, Dealer and Installer:

Please make sure your Dealer/Installer explains and delivers all warning notices, warranty forms and instruction sheets included with DT PROFAB product. DT PROFAB reserves the right to update as necessary, without notice, and will not be held responsible for misprints, changes or variations made by vehicle manufacturers.

Please note that certain mechanical aspects of any suspension lift product may accelerate ordinary wear of original equipment components. The installation of certain DT PROFAB products may void the vehicle's factory warranty as it pertains to certain covered parts; it is the consumer's responsibility to check with their local dealer for warranty coverage before installation of any DT PROFAB product.

Warranty and Return policy:

DT PROFAB warrants its full line of products to be free from defects in workmanship and materials. DT PROFAB's obligation under this warranty is limited to repair or replacement, at DT PROFAB's option, of the defective product. **Any and all costs of removal, installation, freight or incidental or consequential damages are expressly excluded from this warranty.** DT PROFAB is not responsible for damages and/or warranty of other vehicle parts related or non-related to the installation of DT PROFAB product. A consumer who makes the decision to modify his vehicle with aftermarket components of any kind will assume all risk and responsibility for potential damages incurred as a result of their chosen modifications. Warranty coverage does not include consumer opinions regarding ride comfort, fitment and design. Warranty claims can be made directly with DT PROFAB or at any authorized DT PROFAB dealer.

Claims NOT Covered Under DT PROFAB Warranty

- Parts subject to normal wear, to include bushings, bump stops, ball joints, heim joints
- Coating Finish after 90 days
- Discontinued products at DT PRODUCTS, INC/DT PROFAB discretion
- Bent or dented product
- Leaf or coil springs used without proper bump stops
- Products with evident damage caused by abrasion or contact with other items
- Damage caused as a result of not following recommendations or requirements in the installation manuals
- Products used in applications other than listed in DT PROFAB's catalog
- Components or accessories used in conjunction with other manufacturer's systems
- Warranty claims without *Proof of Purchase* DT PROFAB accepts no responsibility for any altered product, improper installation, lack of or improper maintenance, or improper use of our products.



DT PRO FAB
Information & order Info
www.dtprofab.com
Email at sales@dtprofab.com
Phone 928.776.4129